



C.M. SURFACE TREATMENT S.p.A.

PRODUZIONE GRANIGLIATRICI AUTOMATICHE A TURBINA

MODELLI:

A GANCIO CON PASSAGGIO CONTINUO O DISCONTINUO – STAMPA PDF

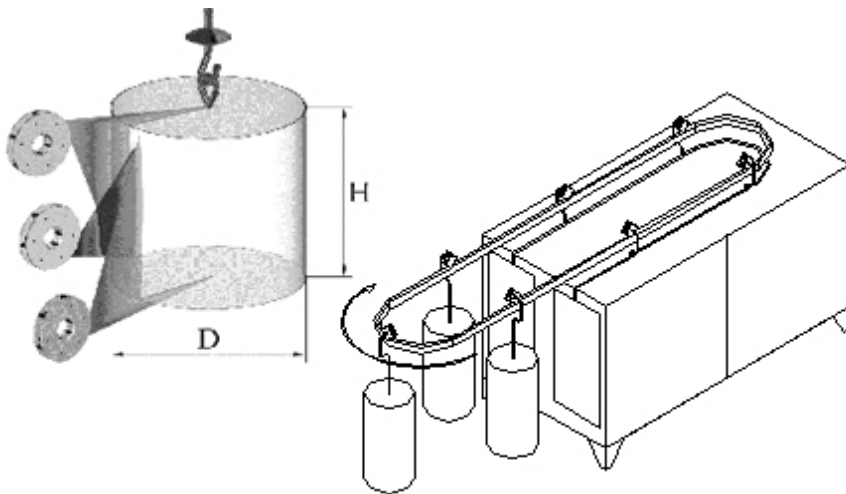

MODELLO	DIMENSIONI UTILI		CARICO GANCIO (kg)	GANCI N°
	D (mm)	H (mm)		
TURBORAIL 1	800	1100	500	14-16
TURBORAIL 1	600	1100	500	19
TURBORAIL 2	1000	1500	700	16-18